



Shock absorber Series Hydrofort – CE

100 – 2000 litre / 10 bar

OLD 0405

Construction

Welded shell in clean steel plate - internal and external rust protection with different paint protective coats - internal food quality epoxy coat - standard external paint orange, other RAL-paints on request - butyl bladder, food quality - gas valve - detachable.

Connection and complete execution in stainless steel on request.

System

The liquid circulates in the bladder and is only in contact with the bladder and flange connection.

Working pressure

10 bar

Precharge pressure

Up to 80% of the minimal working pressure.
Standard execution max. 10 bar, with reinforced bladder up to max. 10 bar.

Temperature range

Standard execution 0°C to + 80°C.
Other ranges on request.

Pressure liquids

Water
Other liquids should be specified with the order.

Mounting / mounting instruction

Vertical on 3 legs.
Leave a free space of 1000 mm over the manhole for removal and installation of the bladder.

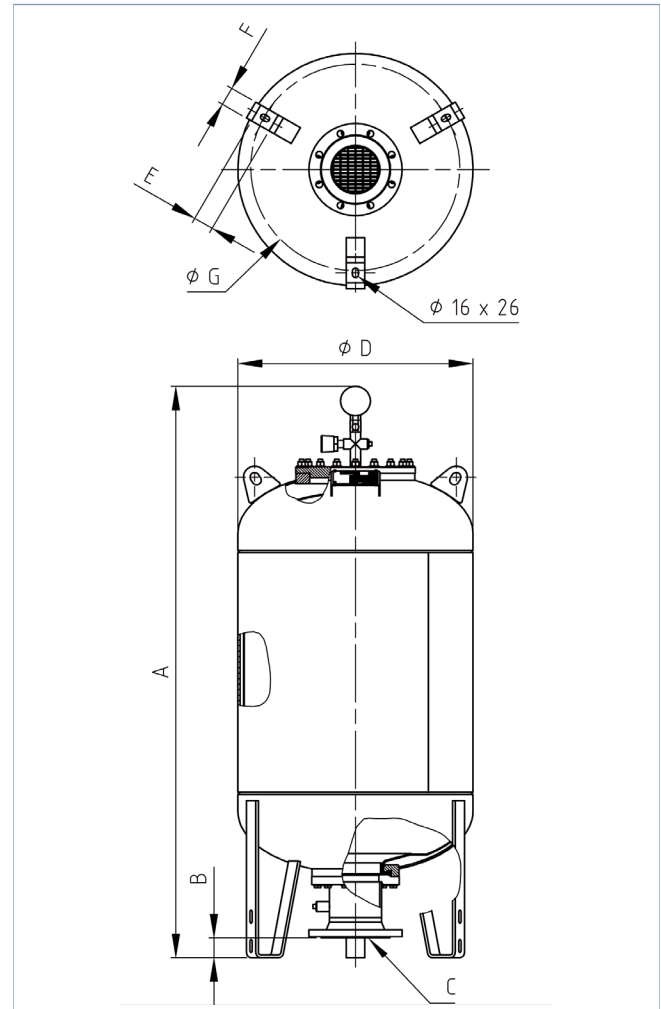

Accessories

Level indicator see data sheet OLD 1115 in chapter 11 "Accessories".

Typ	Gasvol. V ₀ litre	Weight kg	Dimensions in mm					Possible connections C
			A	D	E	F	G	
HFOV 100 – 10 / 90	100	90	1055	630	54	50	560	DN 50 B = 35 – 40 DN 80 B = 39 – 44 DN 100 B = 48 – 53 DN 125 B = 48 – 53 DN 150 B = 45 – 50
HFOV 200 – 10 / 90	200	110	1365	630	54	50	560	
HFOV 300 – 10 / 90	300	135	1690	630	54	50	560	
HFOV 500 – 10 / 90	500	180	2340	630	54	50	560	
HFOV 750 – 10 / 90	750	280	2110	850	80	80	755	
HFOV 1000 – 10 / 90	1000	350	2610	850	80	80	755	
HFOV 1500 – 10 / 90	1500	460	2705	1000	80	100	905	
HFOV 2000 – 10 / 90	2000	575	3405	1000	80	100	905	

OLD 0405 - 7.6.2010 io

OLAER (SCHWEIZ) AG
Bonnstrasse 3, CH - 3186 Dürdingen
Tel. 026 492 70 00, Fax 026 492 70 70
info@olaer.ch
www.olaer.ch

OLAER Austria GmbH
Wachtelstrasse 25, A - 4053 Haid
Tel. +43 7229 803 06, Fax +43 7229 803 06 21
info@olaer.at
www.olaer.at

OLAER CZ s.r.o.
Vídenská 125, CZ - 61900 Brno
Tel. +420 547 125 601 11, Fax +420 547 125 600
info@olaer.cz
www.olaer.cz

OLAER (SCHWEIZ) AG
Magyarországi Fióktelepe
Sugár út 5/1 H - 2500 Esztergom
Tel. +36 (70) 943 8114, Fax +36 (33) 319 954
zsolt.spendel@olaer.hu www.olaer.hu